

H&S PARTS BOOK

S2112 SPREADER

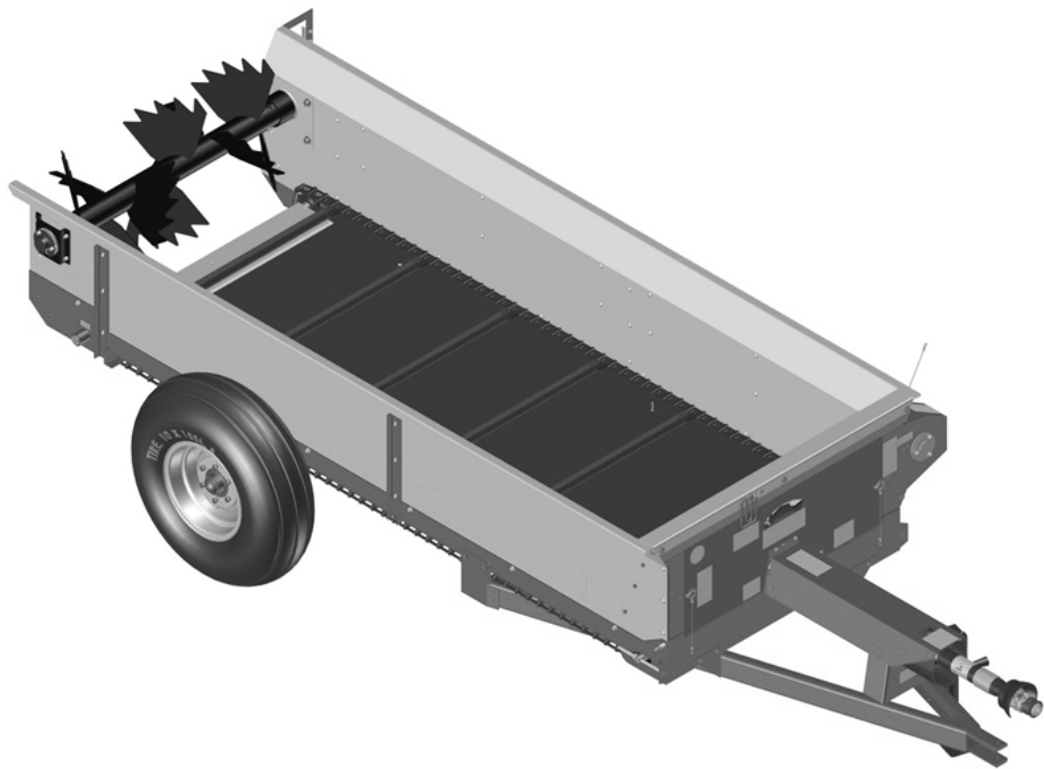

Revision #02
Starting Ser. #711672

Part #71214
HSMFG0417

**P.O. BOX 768, MARSHFIELD, WI 54449
(715) 387-3414 FAX (715) 384-5463
www.hsmfgco.com**

CONTENTS

Instructions For Ordering Parts - About Improvements	1
Figure 1 - Main Frame & Pole Assembly	2-3
Figure 2 - Poly Shield & Components	4-5
Figure 3 - Front Shaft Assembly	6-7
Figure 4 - Front Shields & Components	8-9
Figure 5 - Shifting Components	10-11
Figure 6 - Floor & Hardware.	12-13
Figure 7 - Apron Chain & Front Drive Shaft Assembly	14-15
Figure 8 - Apron Chain & Rear Drive Shaft Assembly.	16-17
Figure 9 - Side Panel Assembly	18-19
Figure 10 - Side Shaft Assembly	20-21
Figure 11 - Shields & Guards	22-23
Figure 12 - Beater Assembly	24-25
Figure 13 - Gearbox.	26-29
Figure 14 - Hub Assembly	30-31
Figure 15 - Pto.	32-33
Figure 16 - Optional Pan.	34-35
Parts Notes	36

INSTRUCTIONS FOR ORDERING PARTS

All service parts should be ordered through your authorized H&S dealer. They will be able to give you faster service if you will provide them with the following

1. Model & Serial number is located in the front center of the Manure Spreader.
2. All reference to left or right apply to the Manure Spreader as viewed from the rear.
3. Parts should not be ordered from illustration only. Please order by complete part number.
4. If your dealer has to order parts - give shipping instructions:

VIA truck - large pieces (please specify local truck lines)

VIA United Parcel Service (include full address)

H&S MFG. CO. INC.
MARSHFIELD, WIS.

MOD. NO.

SER. NO.

DESCR.

PLEASE RECORD NUMBERS FOR YOUR UNIT FOR QUICK REFERENCE

ABOUT IMPROVEMENTS

H&S IS CONTINUALLY STRIVING TO IMPROVE IT'S PRODUCTS

We must therefore, reserve the right to make improvements or changes whenever it becomes practical to do so without incurring any obligation to make changes or additions to the equipment previously sold.

FIGURE 1 MAIN FRAME & POLE ASSEMBLY

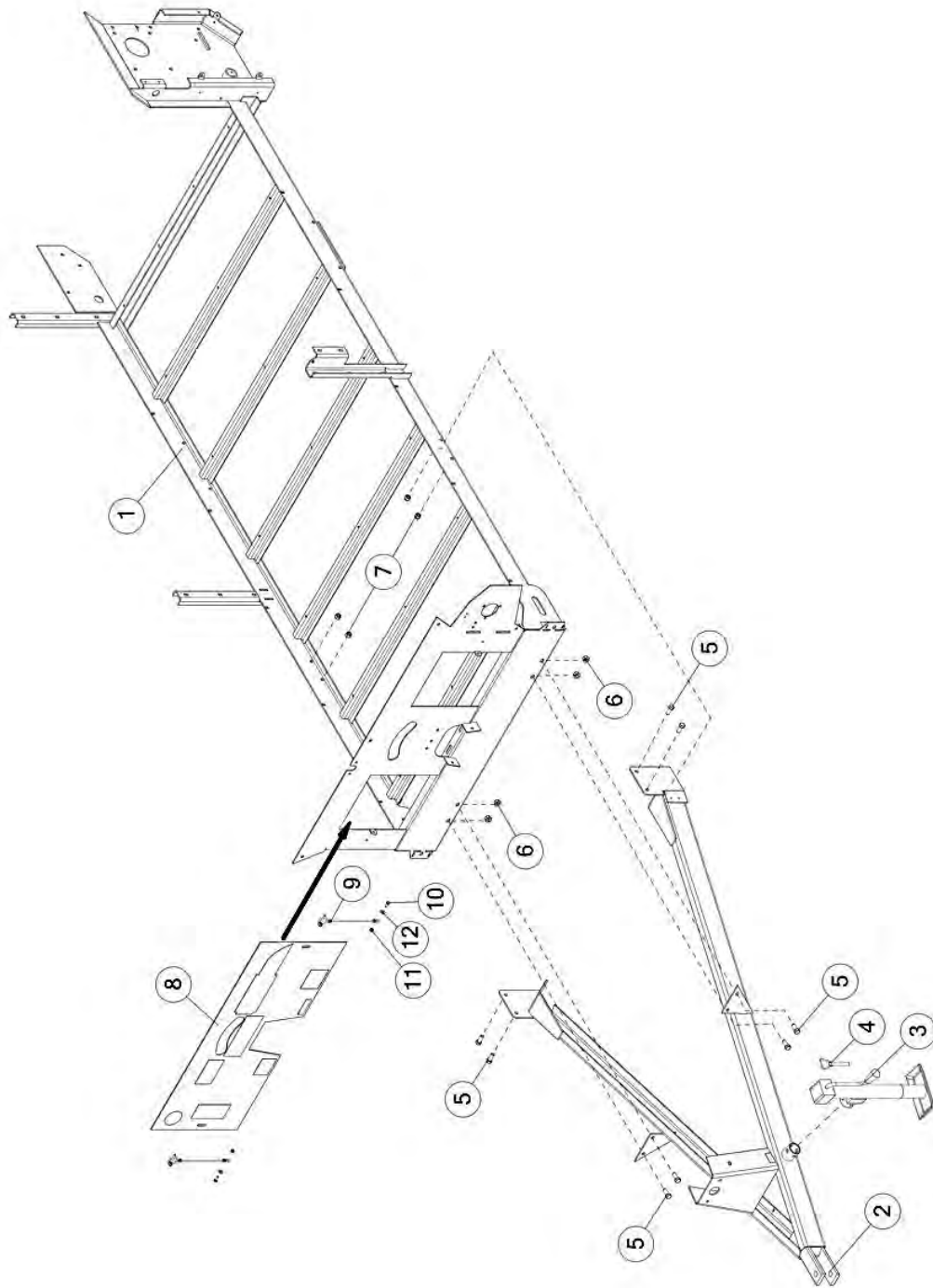

FIGURE 1
MAIN FRAME & POLE ASSEMBLY

<u>ITEM</u>	<u>QTY</u>	<u>PART #</u>	<u>DESCRIPTION</u>
1	1	71996	ASSM, FRAME, MAIN, WITH DECALS
2	1	70994	FRONT POLE WITH DECALS
3	1	12N116	JACK, 2000# SIDE WIND JACK
4	1	12N117	PIN, 0.56, 5.19, JACK
5	8	YBHH16045	BOLT, 1/2-13 X 1-1/4 GR 5
6	4	YNFG16010	HEX NUT, FLANGED, TOP LOCK, 1/2, GR G, ZC
7	4	YNNY16005	HEX NUT, NYLON LOCKNUT, 1/2-13
8	1	72004	POLY PANEL ASSM, FRONT, WITH DECALS
9	2	S122	LANYARD, CLIP PIN CABLE
10	2	YBHH08100	BOLT, 1/4 X 3/4 GR 5
11	2	YNNY08005	HEX NUT, NYLON LOCKNUT, 1/4-20
12	2	YWFL08005	WASHER, FLAT, 1/4 USS

FIGURE 2
POLY SHIELD & COMPONENTS

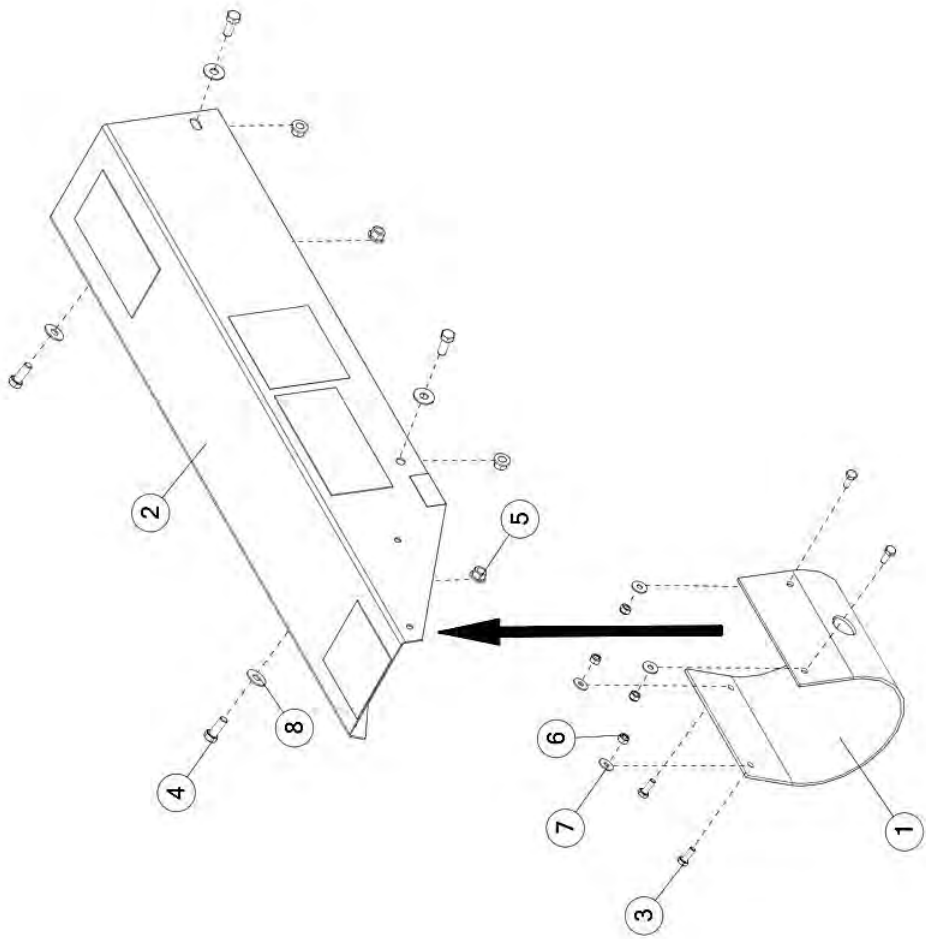

FIGURE 2
POLY SHIELD & COMPONENTS

<u>ITEM</u>	<u>QTY</u>	<u>PART #</u>	<u>DESCRIPTION</u>
1	1	F54	PTO RUBBER
2	1	70989	ASSM, PTO SHIELD WITH DECALS
3	4	YBHH08100	BOLT, 1/4 X 3/4 GR 5
4	4	YBHH12010	BOLT, 3/8 X 1 GR 5
5	4	YNFG12005	3/8-16 TOP LOCK FLANGE NUT, GR.F, ZINC
6	4	YNNY08005	HEX NUT, NYLON LOCKNUT, 1/4-20
7	4	YWFL08005	WASHER, FLAT, 1/4 USS
8	4	YWFL12005	WASHER, FLAT, 3/8 USS

FIGURE 3
FRONT SHAFT ASSEMBLY

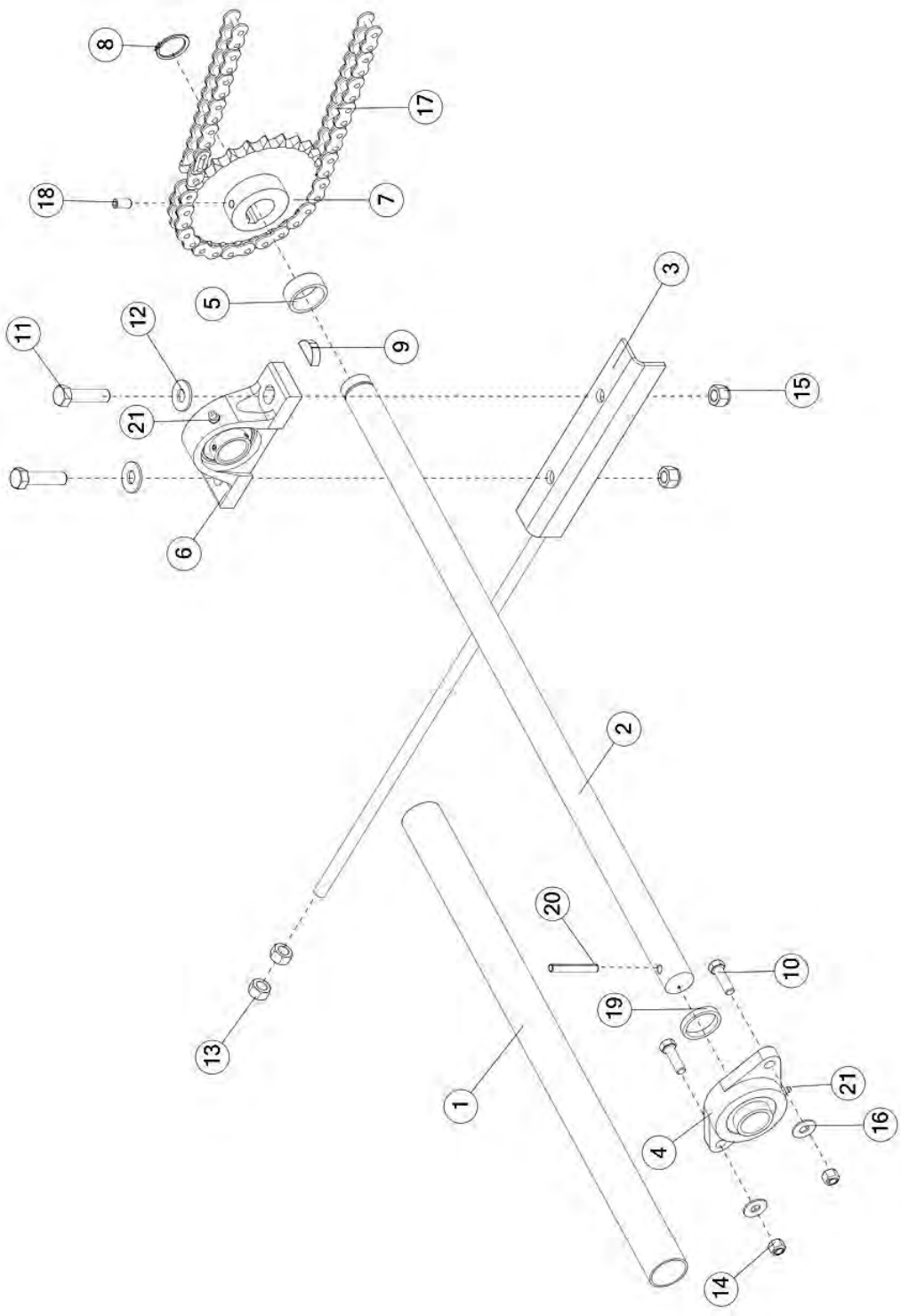

FIGURE 3

FRONT SHAFT ASSEMBLY

<u>ITEM</u>	<u>QTY</u>	<u>PART #</u>	<u>DESCRIPTION</u>
1	1	68897	TUBE, RND, STR, 1.88 X 0.15 X 25.5, PVC
2	1	68787	SHAFT, RND, 1.25 X 32.75
3	1	68894	WLDMT, TITEN, ROD
4	1	12N29	BRG, 3.13 X 1.25 X 5.59, FLANGE
5	1	12N30	FRONT SHAFT SPACER
6	1	17G7	BEARING, PILLOW BLOCK UNIT, 1.25" SHAFT
7	1	23N70	SPKT, 60, B, 25, 1.25 SHAFT
8	1	F73	SNAP RING
9	1	5B9	KEY, WDF, 0.38 X 0.53 X 1.25
10	2	YBHH12035	BOLT, 3/8"-16 X 1-1/4" GR. 5
11	2	YBHH16065	BOLT, 1/2 X 2 GR 5
12	2	YWFL16005	WASHER, FLAT, 1/2 USS
13	2	YNHX16005	HEX NUT, 1/2
14	2	YNTL12005	HEX NUT, TOP LOCK, 3/8-16
15	2	YNNY16005	HEX NUT, NYLON LOCKNUT, 1/2-13
16	2	YWFL12005	WASHER, FLAT, 3/8 USS
17	1	70044	CHAIN, ROLL, #60 X 106
18	1	YSKP12035	SETSCR, SCKT, KNRD CUP PT 3/8-16 X 3/4
19	1	71278	TUBE, RND, STR, 1.66 X 0.14 X 0.25
20	1	YPEX10020	EXPANSION PIN, 5/16 X 2-1/4
21	2	G89	ZERK, 1/4"-28 STRAIGHT

FIGURE 4 FRONT SHIELDS & COMPONENTS

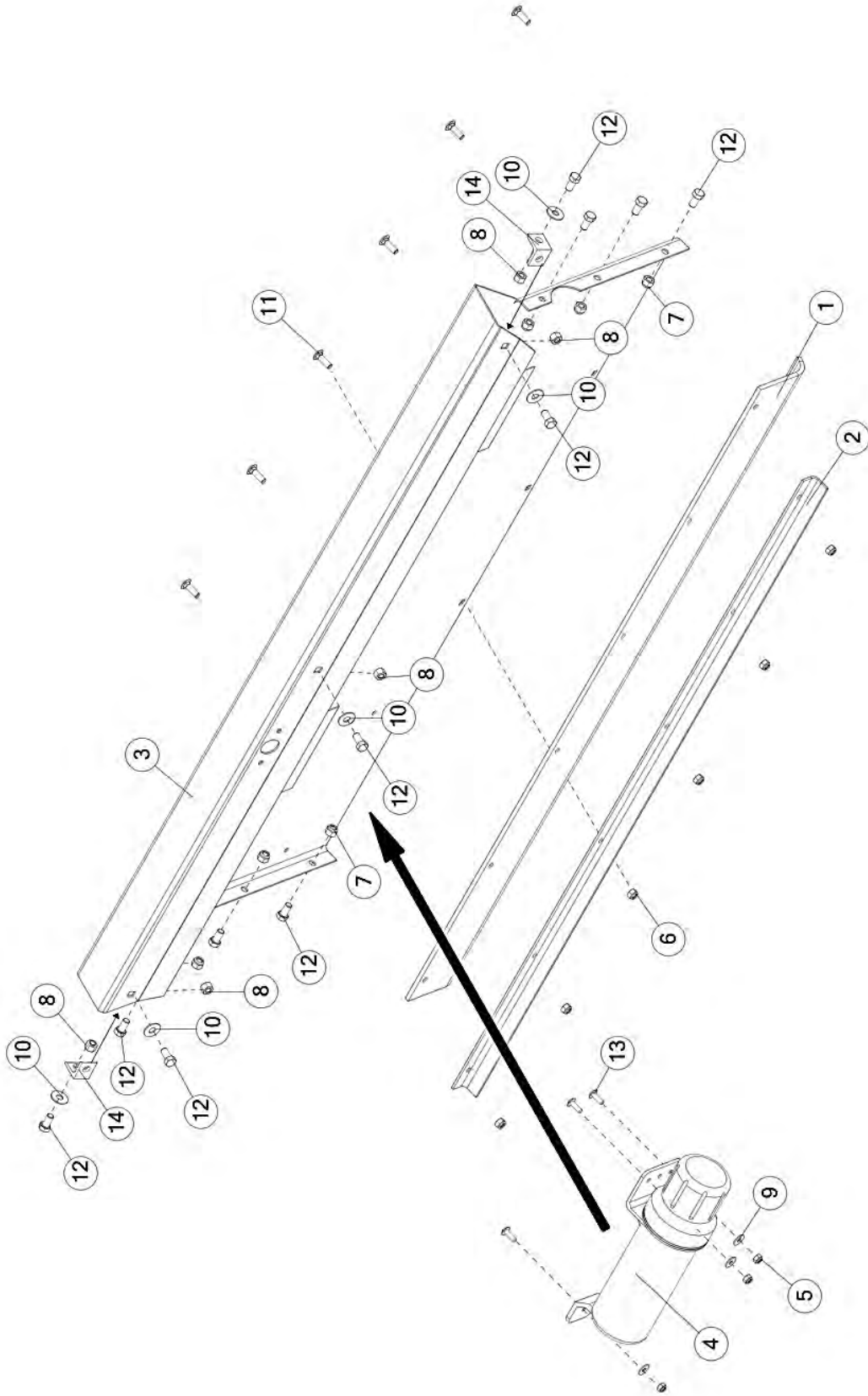

FIGURE 4

FRONT SHIELDS & COMPONENTS

<u>ITEM</u>	<u>QTY</u>	<u>PART #</u>	<u>DESCRIPTION</u>
1	1	12N69	FRONT RUBBER
2	1	12N97	ANGLE FOR RUBBER
3	1	72003	ASSM, PANEL, FRONT, WITH DECALS
4	1	S522	MANUAL HOLDER
5	3	YNNY08005	NUT, HEX, 1/4-20, LKNY, G2, ZC
6	6	YNNY10005	NUT, HEX, 5/16-18, LKNY, G2, ZC
7	6	YNNY12005	NUT, HEX, 3/8-16, LKNY, G2, ZC
8	5	YNTL12005	NUT, HEX, 3/8-16, LKTL, C, ZC
9	3	YWFL08005	WASHER, FLAT, 1/4 USS
10	5	YWFL12005	WASHER, FLAT, 3/8 USS
11	6	YBCR10010	BOLT, CARR, 5/16-18 X 1.00, G5, ZC
12	11	YBHH12135	BOLT, HEX, 3/8-16 X 3/4, G5, ZC
13	3	YSTM08004	1/4-20 X 3/4 TRUSS HEAD MACHINE SCREW
14	2	WM135	TIGHTENER ANGLE

FIGURE 5

SHIFTING COMPONENTS

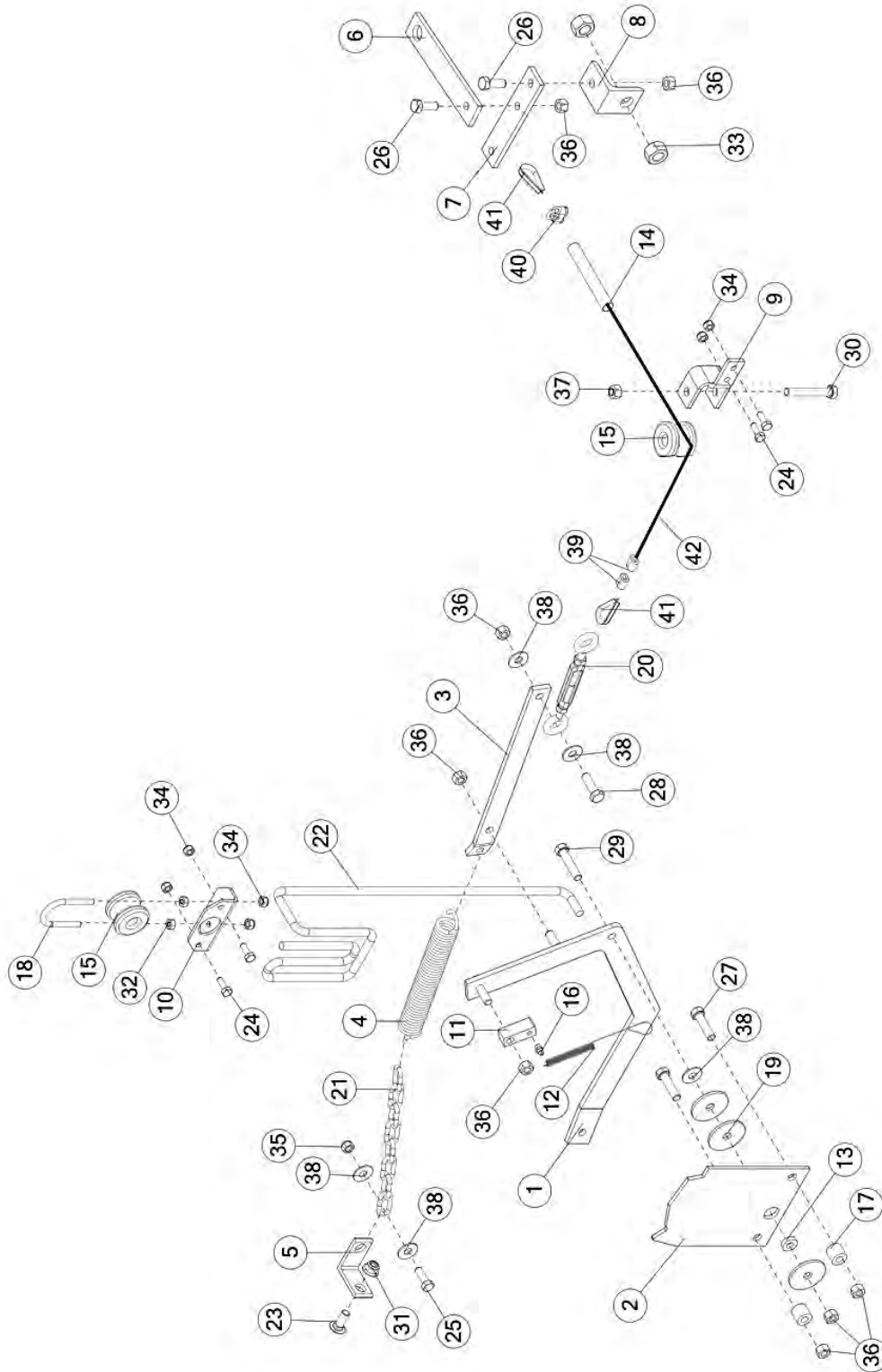

FIGURE 5

SHIFTING COMPONENTS

<u>ITEM</u>	<u>QTY</u>	<u>PART #</u>	<u>DESCRIPTION</u>
1	1	70861	WLDMT, LEVER, SHIFTER
2	1	23N283	STOP BRACKET
3	1	23N281	BRKT, PIVOT LINK
4	1	10R14	SPRG, COIL, 8.5, 25, TENS
5	1	17G177	BRKT, SPRG, MOUNT
6	1	23N289	SHIFTER ROD LEVER FULCRUM
7	1	23N290	BRKT, SHIFTER ROD
8	1	23N291	BRKT, ROD, SHIFTER
9	1	71566	BRKT, CABLE GUIDE
10	1	71972	CABLE GUIDE BRKT, FRONT
11	1	23N282	BRKT, 5/8, SHIFTERDOG
12	1	23N284	SPRG, EXT, COIL, 5.50 X 6.95, 1.20, SHIFTER DOG
13	1	23N297	TUBE, RND, STR, 0.75 X 0.19 X 0.21, DOM
14	1	72120	ELEC HARNESS, HEAT SHRINK, 4.00 X 0.50
15	2	F33	SIDE CABLE GUIDE
16	1	G89	ZERK, 1/4"-28 STRAIGHT
17	2	ST81	EXTENSION SPACER, 11/16"
18	1	YBPU08005	PIPE U BOLT, 1/4 X 3/4
19	3	YWCU12005	WASHER, CUSTOM, FLAT
20	1	F84	ASSM, TURNBUCKLE
21	1	17G178	ASSM, CHAIN
22	1	23N183	ROPE, 0.38 X 126
23	1	YBCR12010	CARR. BOLT, 3/8 X 1 GR. 5
24	4	YBHH08100	BOLT, HEX, 1/4-20 X 3/4, G5, ZC
25	1	YBHH10010	BOLT, HEX, 5/16-18 X 1, G5, ZC
26	2	YBHH12010	BOLT, HEX, 3/8-16 X 1, G5, ZC
27	2	YBHH12025	BOLT, HEX, 3/8-16 X 1-1/2, G5, ZC
28	1	YBHH12035	BOLT, HEX, 3/8-16 X 1-1/4, G5, ZC
29	1	YBHH12060	BOLT, HEX, 3/8-16 X 1-3/4, G5, ZC
30	1	YBHH12090	BOLT, HEX, 3/8-16 X 2-1/2, G5, ZC
31	1	YNFG12006	NUT, FLG, 3/8-16, LKNY, F, ZC
32	2	YNHX08005	NUT, HEX, 1/4-20, NA, A, ZC
33	2	YNHX20005	NUT, HEX, 5/8-11, NA, A, ZC
34	6	YNNY08005	NUT, HEX, 1/4-20, LKNY, G2, ZC
35	1	YNNY10005	NUT, HEX, 5/16-18, LKNY, G2, ZC
36	8	YNRL12005	NUT, HEX, 3/8-16, LKRS, A, ZC
37	1	YNTL12005	NUT, HEX, 3/8-16, LKTL, C, ZC
38	5	YWFL12005	WASHER, FLAT, 3/8 USS
39	2	71279	SLEEVE, 0.13 X 0.63
40	1	BFR220	CLAMP, 3/16" CABLE
41	2	ES14	THIMBLE
42	1	70619	CABLE, 0.19 X141.37, SHIFTER

FIGURE 6 FLOOR & HARDWARE

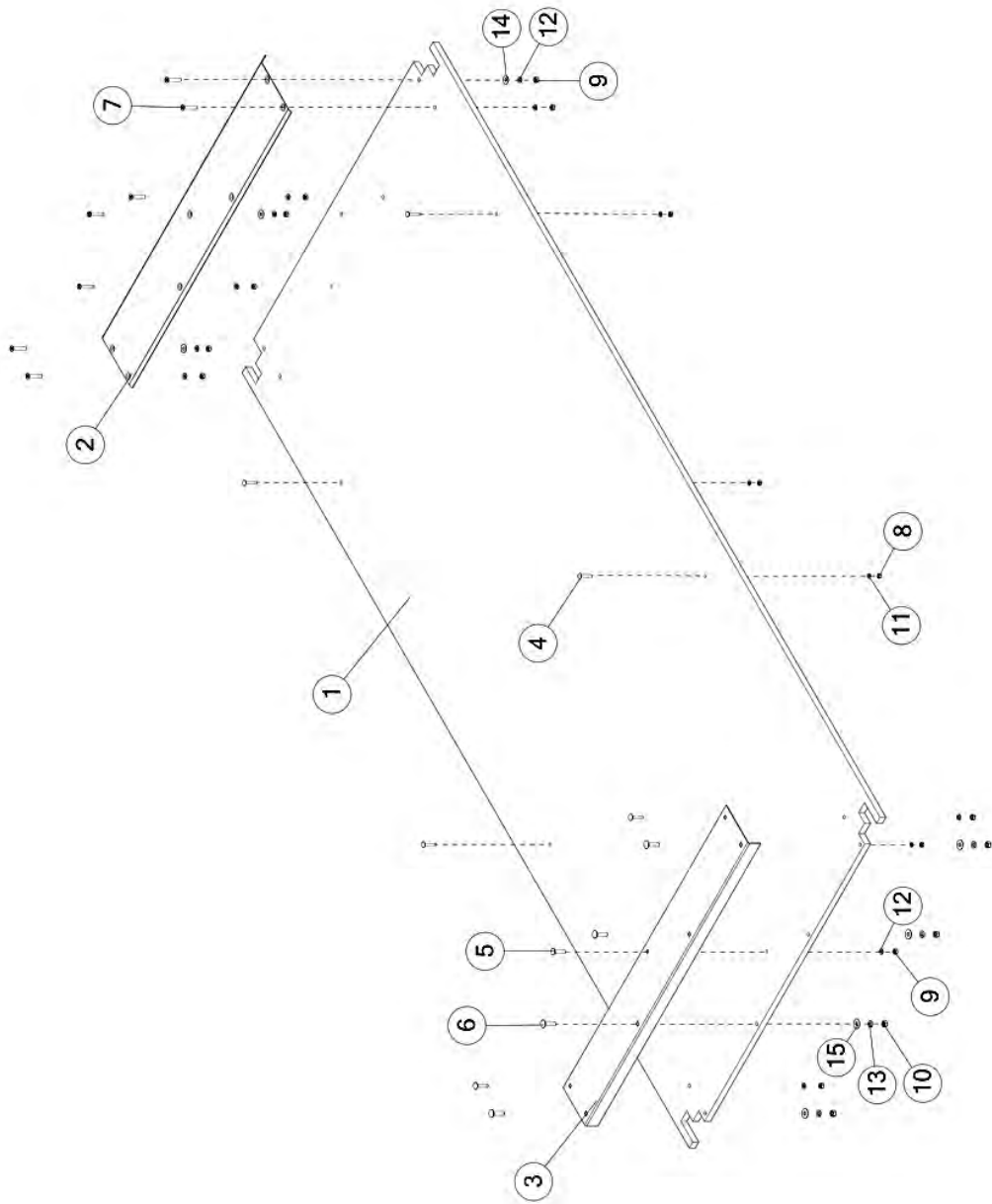

FIGURE 6

FLOOR & HARDWARE

<u>ITEM</u>	<u>QTY</u>	<u>PART #</u>	<u>DESCRIPTION</u>
1	1	12N93	POLY PLYWOOD, 125 BU FLOOR, 7 PLY - 5/8" X 47-3/4" X 113-1/2"
2	1	72143	GALV. PANEL, REAR FLOOR BRACE
3	1	12N94	FRONT FLOOR BRACE
4	4	YBCR08011	CARR. BOLT, 1/4 X 1-1/2 GR 5 FULL THREAD
5	3	YBCR10015	CARR. BOLT, 5/16 X 1-1/2 GR. 5
6	4	YBCR12015	CARR. BOLT, 3/8 X 1-1/2 GR 5
7	7	YSFM10010	FLAT HEAD MACH, SCREW, 5/16 X 1-3/4
8	4	YNHX08007	HEX NUT, 1/4-20 GR 5
9	10	YNHX10010	HEX NUT, 5/16-18 GR 5
10	4	YNHX12005	HEX NUT, 3/8-16 GR 2
11	4	YWLO08005	WASHER, LOCK, 1/4
12	10	YWLO10005	WASHER, LOCK, 5/16
13	4	YWLO12005	WASHER, LOCK, 3/8
14	3	YWFL10005	WASHER, FLAT, 5/16 USS
15	4	YWFL12005	WASHER, FLAT, 3/8 USS

FIGURE 7 **APRON CHAIN & FRONT DRIVE SHAFT ASSEMBLY**

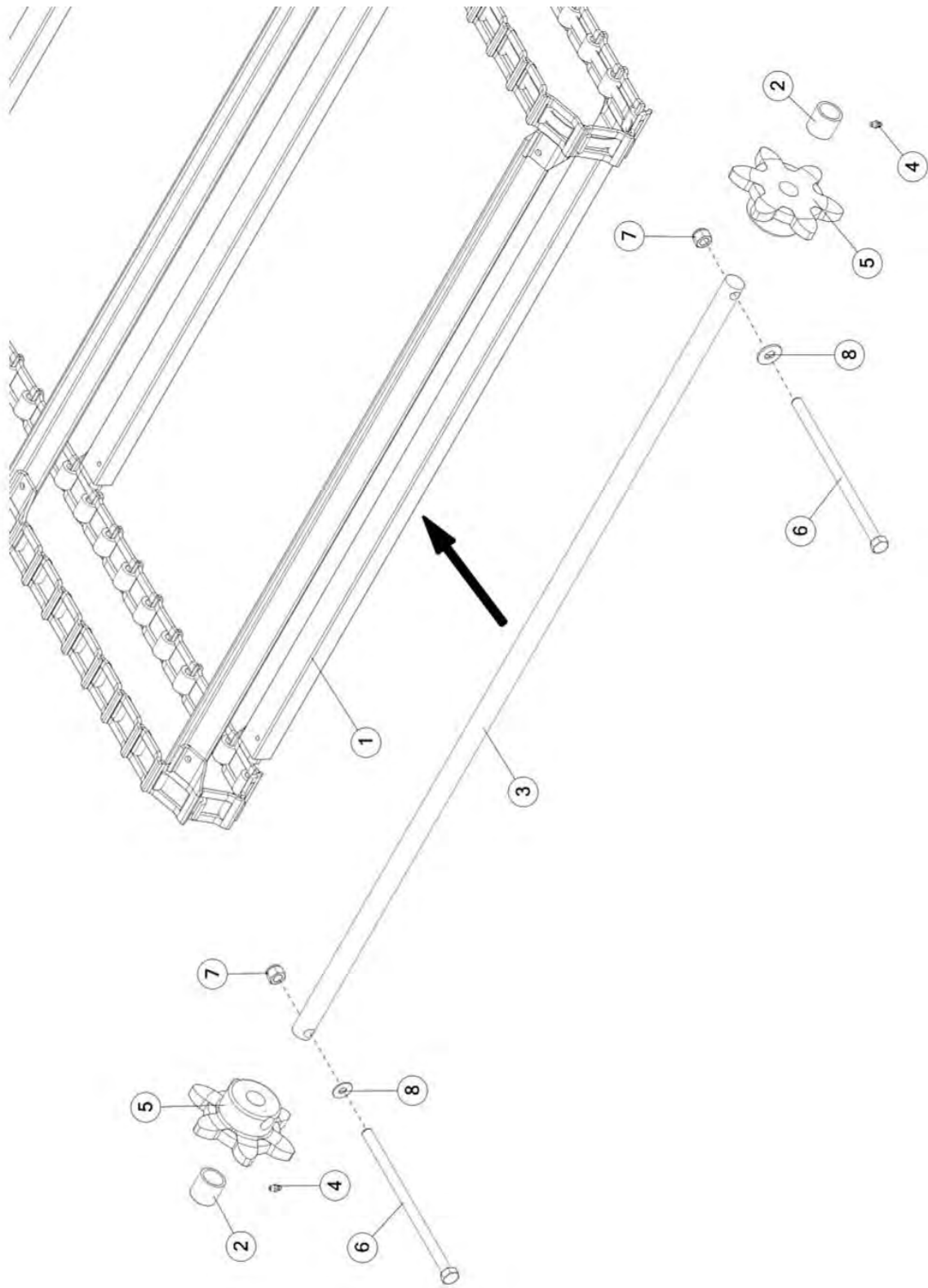

FIGURE 7

APRON CHAIN & FRONT DRIVE SHAFT ASSEMBLY

<u>ITEM</u>	<u>QTY</u>	<u>PART #</u>	<u>DESCRIPTION</u>
1	1	12N64	ASSM, APRON CHAIN
*	1	12N63	ASSM, 67XH SLAT W/ATT LINK
*	1	11S26	ATT. LINK LH 67XH
*	1	11S27	ATT. LINK RH 67XH
*	1	11S29	CONNECTOR LINK 67XH
2	2	12N66	IDLER SPACER
3	1	12N67	FRONT IDLER SHAFT
4	2	G89	ZERK, 1/4"-28 STRAIGHT
5	2	12N65	SPKT, APRON, 6
6	2	YBHH16190	BOLT, 1/2 X 9-1/2, 6-3/4 THREAD LENGTH
7	2	YNNY16005	HEX NUT, NYLON LOCKNUT, 1/2-13
8	2	YWFL16005	WASHER, FLAT, 1/2 USS

***MEANS NOT SHOWN**

FIGURE 8
APRON CHAIN & REAR DRIVE SHAFT ASSEMBLY

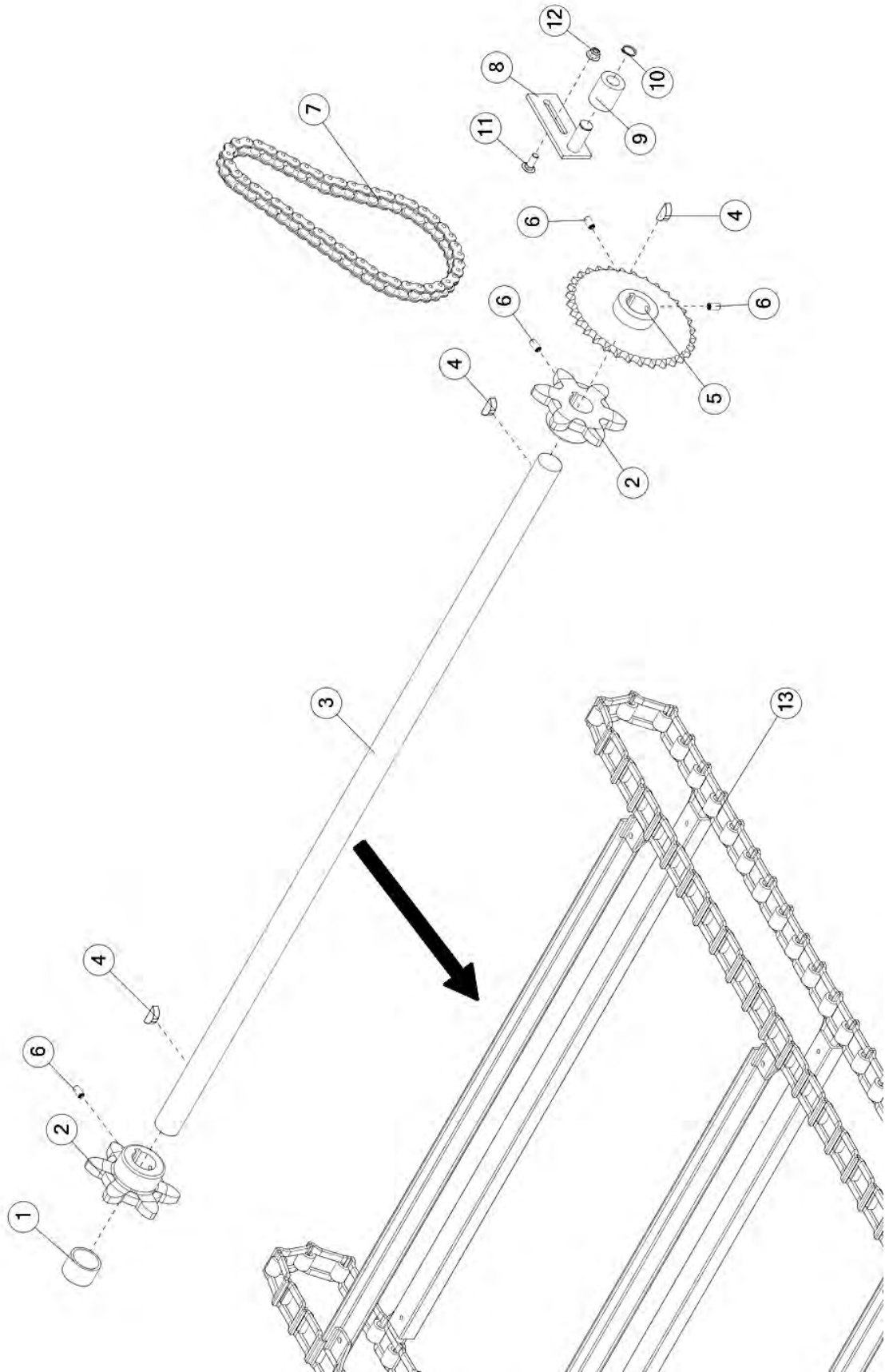

FIGURE 8

APRON CHAIN & FRONT DRIVE SHAFT ASSEMBLY

<u>ITEM</u>	<u>QTY</u>	<u>PART #</u>	<u>DESCRIPTION</u>
1	1	A39	DRIVE SHAFT SPACER
2	2	A4	DRIVE SHAFT SPROCKET
3	1	72146	DRIVE SHAFT, 1.50 X 53.75
4	3	5B9	KEY, WDF, 0.38 X 0.53 X 1.25
5	1	69759	SPKT, 60, B, 32, 1.50 SHAFT
6	4	YSKP12035	SETSCR, SCKT, KNRD CUP PT 3/8-16 X 3/4
7	1	70045	CHAIN, ROLL, #60 X 49
8	1	L10R35	ASSY, TIGHTENER BRACKET
9	1	23N238	CHAIN TIGHTENER ROLLER
10	1	10R32	SNAP RING
11	1	YBCR12010	CARR. BOLT, 3/8 X 1 GR. 5
12	1	YNFG12006	HEX NUT, FLANGE, NYLOCK, 3/8-16, GR F, ZINC ASSM,
13	1	12N64	APRON CHAIN
*	1	12N63	ASSM, 67XH SLAT W/ATT LINK
*	1	11S26	ATT. LINK LH 67XH
*	1	11S27	ATT. LINK RH 67XH
*	1	11S29	CONNECTOR LINK 67XH

***MEANS NOT SHOWN**

FIGURE 9 SIDE PANEL ASSEMBLY

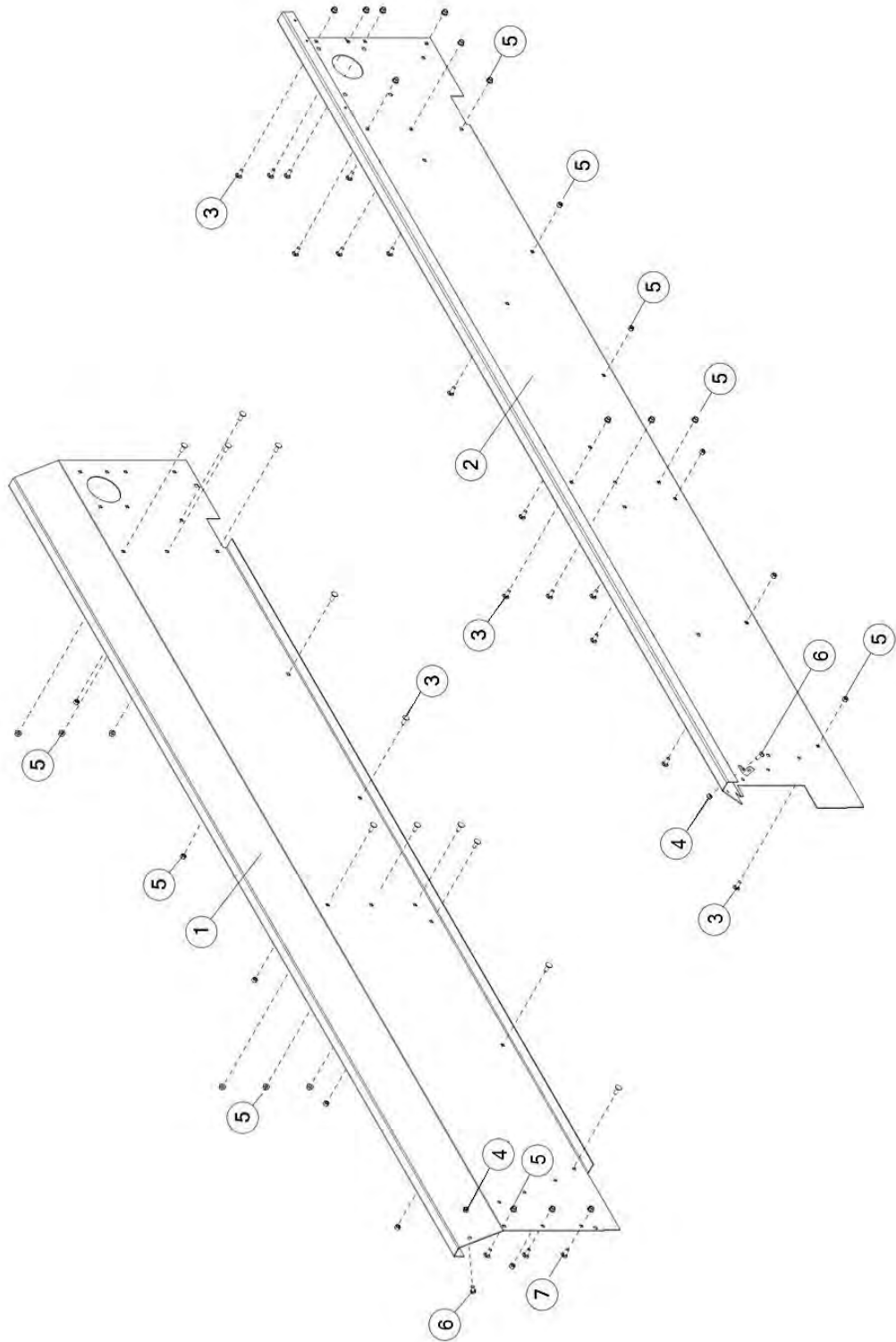

FIGURE 9
SIDE PANEL ASSEMBLY

<u>ITEM</u>	<u>QTY</u>	<u>PART #</u>	<u>DESCRIPTION</u>
1	1	70990	ASSM, PANEL WITH DECALS, RH
2	1	70986	ASSM, PANEL WITH DECALS, LH
3	31	YBCR12065	BOLT, CARR, 3/8-16 X 3/4, G5, ZC
4	2	YBHH12010	BOLT, HEX, 3/8-16 X 1, G5, ZC
5	32	YNFG12006	HEX NUT, FLANGE, NYLOCK, 3/8-16, GR F, ZINC
6	2	YNTL12005	HEX NUT, TOP LOCK, 3/8-16
7	1	YBCR12010	CARR. BOLT, 3/8 X 1 GR. 5

FIGURE 10 SIDE SHAFT ASSEMBLY

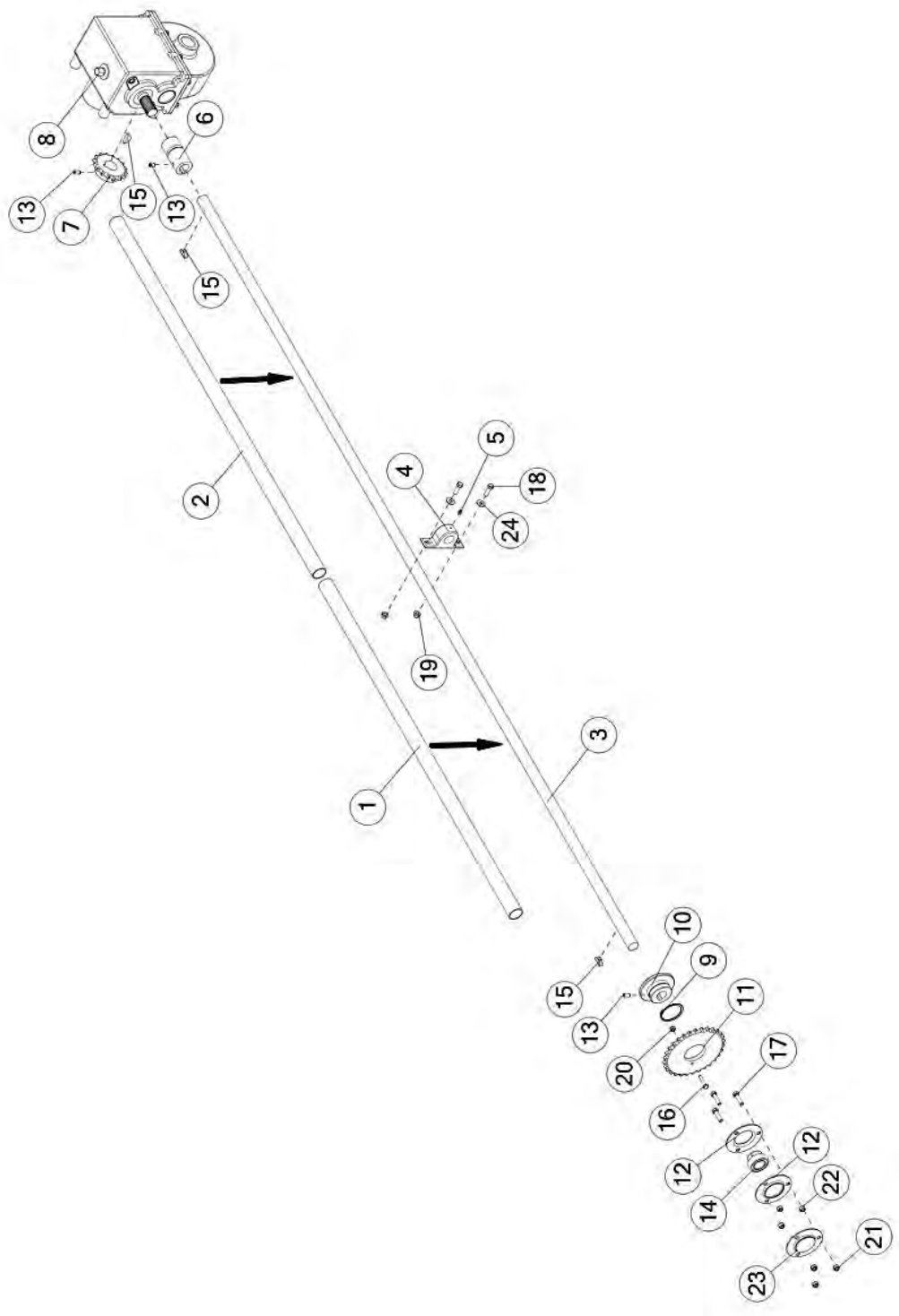

FIGURE 10

SIDE SHAFT ASSEMBLY

<u>ITEM</u>	<u>QTY</u>	<u>PART #</u>	<u>DESCRIPTION</u>
1	1	68898	TUBE, RND, STR, 1.88 X 0.15 X 52.65, PVC
2	1	68899	TUBE, RND, STR, 1.88 X 0.15 X 56.13, PVC
3	1	69905	SHAFT, RND, 1.25, 119.13
4	1	12N36	PILLOW BLOCK 1.25in
5	1	G89	ZERK, 1/4"-28 STRAIGHT
6	1	17G65	ASSY, COUPLER
7	1	17G67	SPKT, 60, B, 16, 1.50 SHAFT
8	1	17G142	ASSM, 2 SPEED GEARBOX
9	1	23N189	STANDARD EXTERNAL SNAP RING, 2.62"
10	1	23N190	SHEAR HUB
11	1	23N191	SPKT, 60, A, 30, 2.625 SHAFT
12	1	F14	FLANGE, BEARING, Ø4.44 OD, Ø2.24
13	3	YSKP12035	SET SCREW, SCKT, KNRD CUP PT 3/8-16 X 3/4
14	1	12N122	BRG, 2.441, 1.250, 1.41, BALL,
15	3	5B9	INSERT KEY, WDF, 0.38 X 0.53 X 1.25
16	3	YBHH10030	BOLT, 5/16-18 X 1-1/2 GR 5
17	3	YBHH12025	BOLT, 3/8-16 X 1-1/2 GR 5
18	2	YBHH12035	BOLT, 3/8"-16 X 1-1/4" GR. 5
19	2	YNFG12005	3/8-16 TOP LOCK FLANGE NUT, GR.F, ZINC
20	1	YNNY10005	HEX NUT, NYLON LOCKNUT, 5/16-18
21	3	YNNY12005	HEX NUT, NYLON LOCKNUT, 3/8
22	3	YNTL12005	HEX NUT, TOP LOCK, 3/8-16
23	1	23N308	SECOND BEATER FLANGE GUARD
24	2	YWFL12005	WASHER, FLAT, 3/8 USS

FIGURE 11
SHIELDS & GUARDS

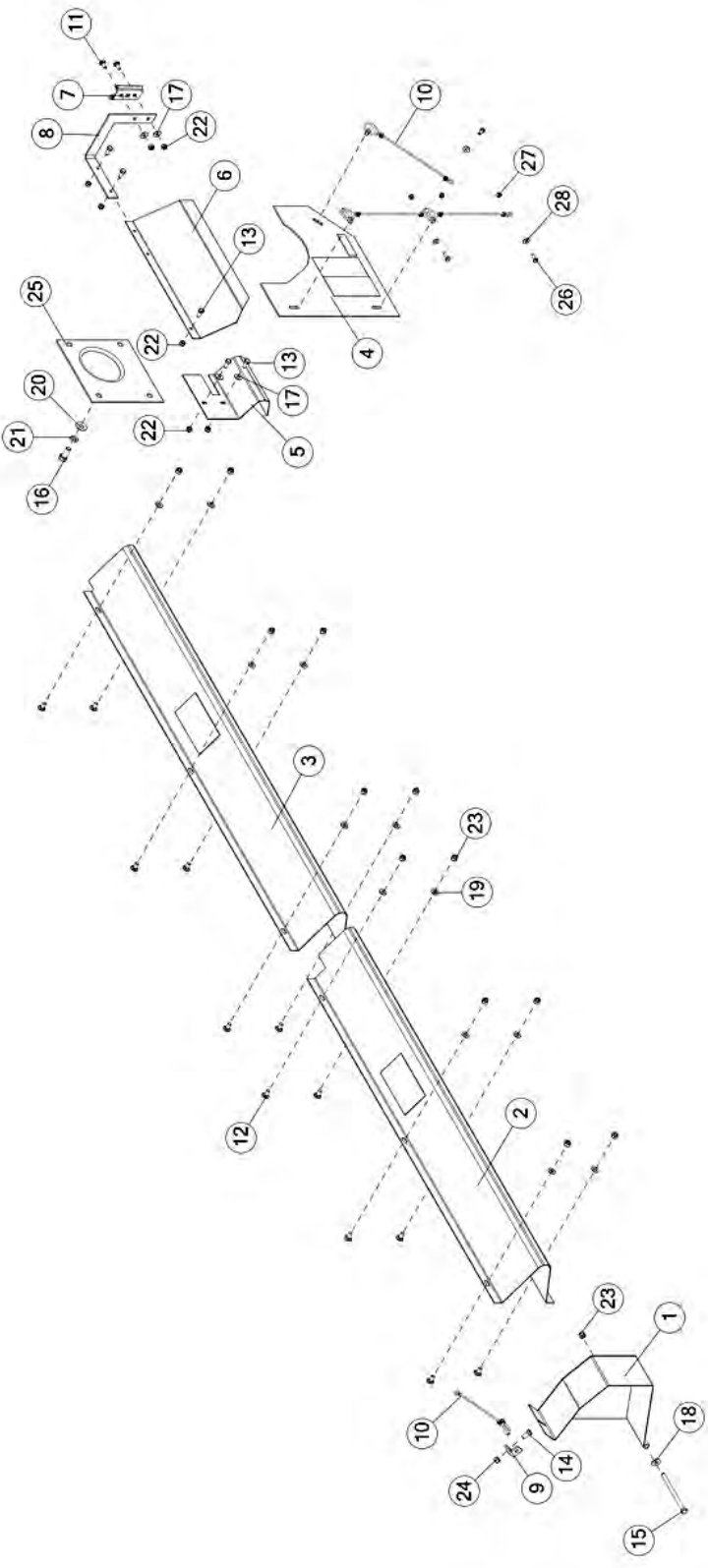

FIGURE 11

SHIELDS & GUARDS

<u>ITEM</u>	<u>QTY</u>	<u>PART #</u>	<u>DESCRIPTION</u>
1	1	70985	ASSM, SPKT SHIELD WITH DECALS
2	1	70984	ASSM, SHIELD, FRONT, WITH DECALS
3	1	70983	ASSM, SHIELD, REAR, WITH DECALS
4	1	72138	ASSM, POLY SHIELD WITH DECALS
5	1	69959	SHLD, COUPLER, 10.85 X 6.75 X 0.08
6	1	70980	ASSM, GRBX SHIELD WITH DECALS
7	1	F97	SMV BRACKET
8	1	70060	BRKT, SMV
9	1	F92	FRONT SHIELD BRACKET
10	4	S122	LANYARD, CLIP PIN CABLE
11	2	YBCR10030	CARR. BOLT, 5/16 X 3/4 GR 5
12	12	YBCR12065	CARR. BOLT, 3/8 X 3/4 GR 5
13	5	YBHH10105	BOLT, 5/16 X 3/4 GR 5
14	1	YBHH12135	BOLT, 3/8 X 3/4 GR 5
15	1	YBHH12215	BOLT, 3/8 X 5-1/2 GR 5
16	4	YBHH16045	BOLT, 1/2-13 X 1-1/4 GR 5
17	4	YWFL10005	WASHER, FLAT, 5/16 USS
18	1	YWFL12005	WASHER, FLAT, 3/8 USS
19	12	YWFL12010	WASHER, FLAT, 3/8 SAE, GR 8, YELLOW ZINC
20	4	YWFL16005	WASHER, FLAT, 1/2 USS
21	4	YWLO16005	WASHER, LOCK, 1/2
22	7	YNNY10005	HEX NUT, NYLON LOCKNUT, 5/16-18
23	13	YNNY12005	HEX NUT, NYLON LOCKNUT, 3/8
24	1	YNTL12005	HEX NUT, TOP LOCK, 3/8-16
25	1	69964	PLT, BEATER FLARE, 9.50 X 9.50 X 0.14
26	3	YBHH08100	BOLT, HEX, 1/4-20 X 3/4, G5, ZC
27	3	YNNY08005	NUT, HEX, 1/4-20, LKNY, G2, ZC
28	3	YWFL08005	WASHER, FLAT, 1/4 USS

FIGURE 12 BEATER ASSEMBLY

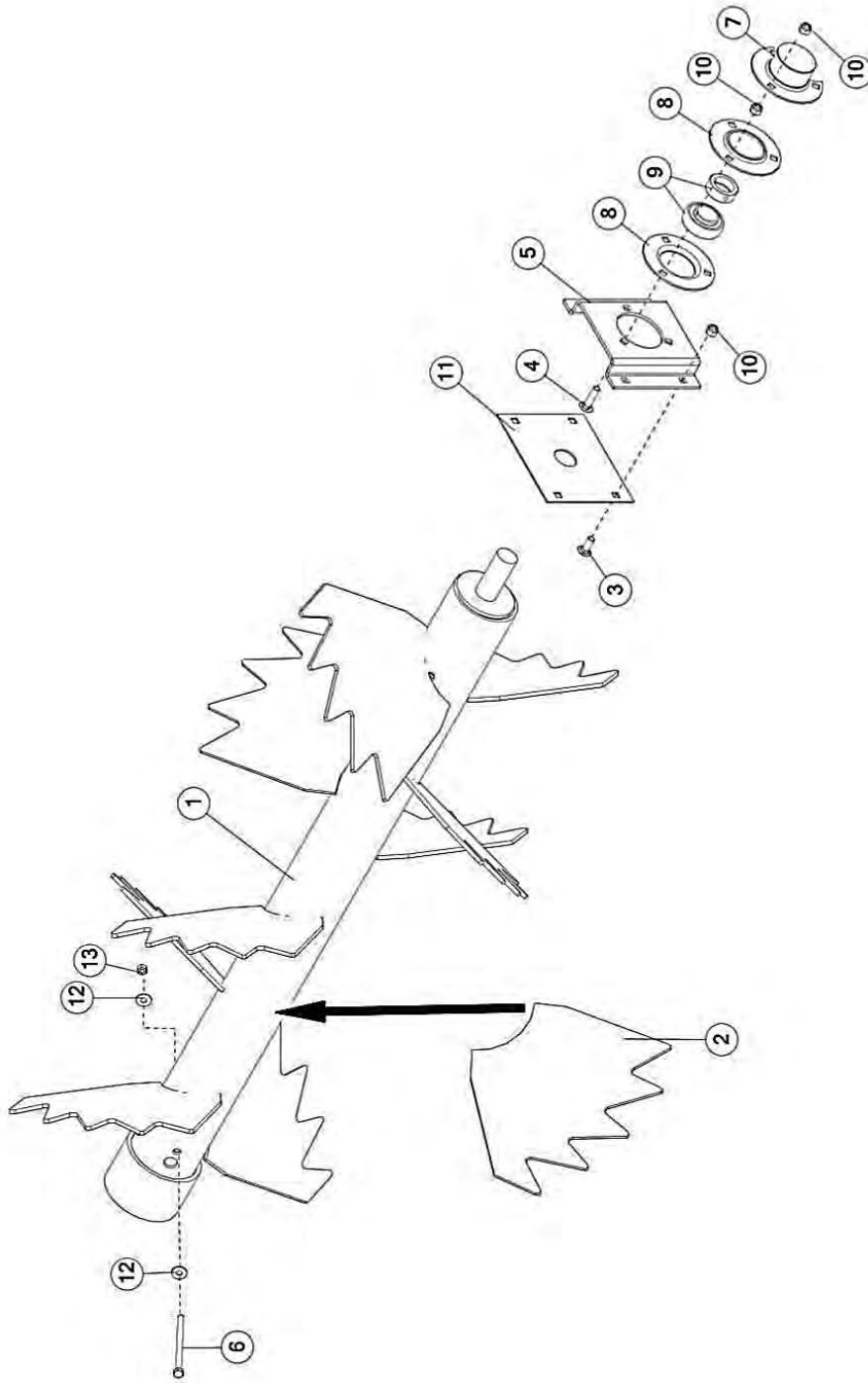

FIGURE 12

BEATER ASSEMBLY

<u>ITEM</u>	<u>QTY</u>	<u>PART #</u>	<u>DESCRIPTION</u>
1	1	69962	WLDMT, BEATER
2	10	12N39	BEATER BLADE
3	4	YBCR12010	CARR. BOLT, 3/8 X 1 GR. 5
4	3	YBCR12015	BOLT, 3/8-16 X 1-1/2 GR 5
5	1	70993	ASSM, SHAFT SUPPORT WITH DECAL
6	1	YBHH10130	BOLT, 5/16 X 5 GR 5
7	1	F95	ASSY, BEARING FLANGE GUARD
8	2	F14	FLANGE, BEARING, Ø4.44 OD, Ø2.24
9	1	12N122	BRG, 2.441, 1.250, 1.41, BALL, INSERT
10	10	YNNY12005	HEX NUT, NYLON LOCKNUT, 3/8
11	1	55235	BEATER SIDE PLATE
12	2	YWFL10005	WASHER, FLAT, 5/16 USS
13	1	YNL10005	HEX NUT, TOP LOCK, 5/16-18

FIGURE 13
GEARBOX

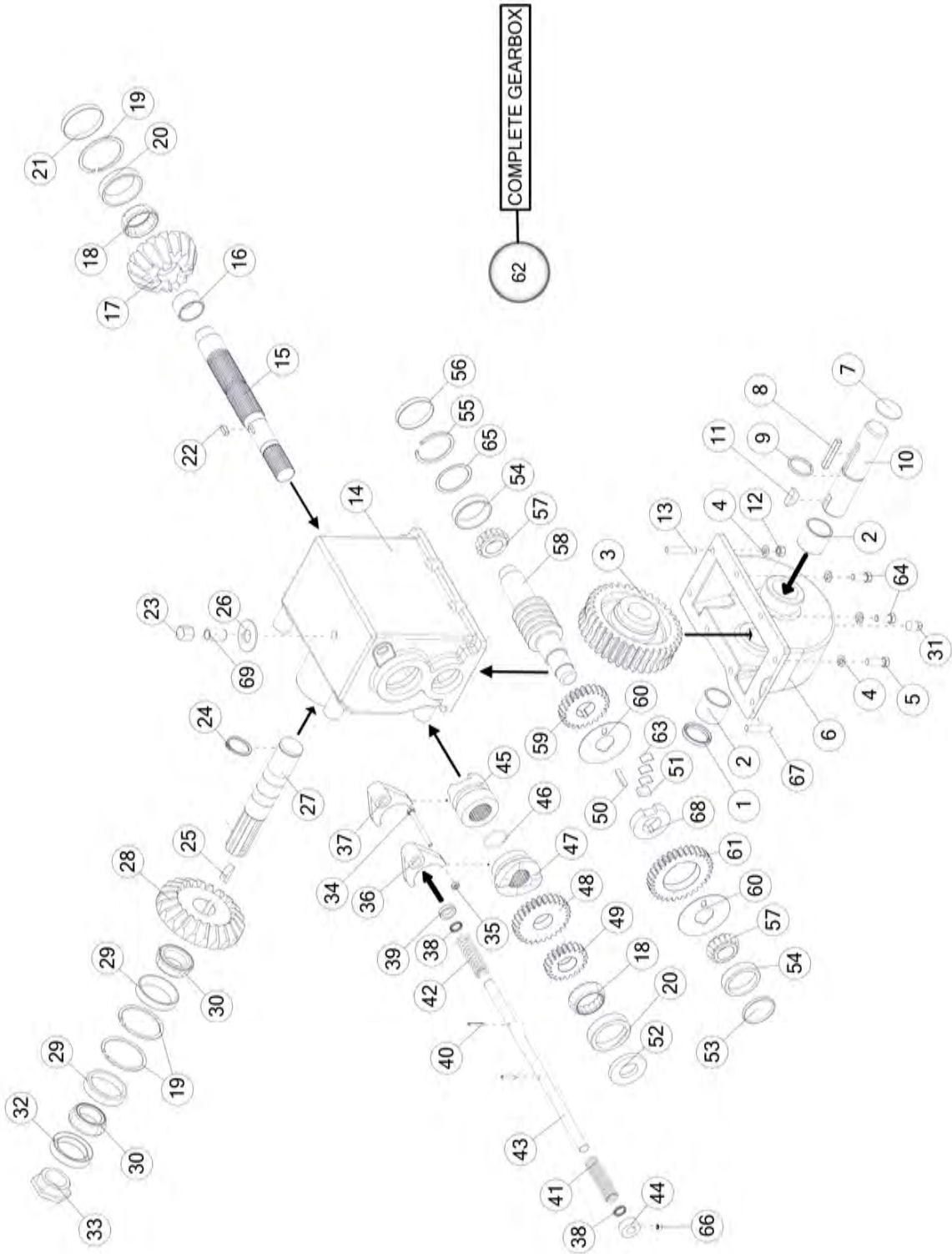

FIGURE 13 GEARBOX

<u>ITEM</u>	<u>QTY</u>	<u>PART #</u>	<u>DESCRIPTION</u>
1	1	17G133	SEAL, 1.88 X 1.50 X 0.25
2	2	17G134	BSH, 1.75 X 1.50 X 1.50, BRZ
3	1	17G137	GEAR, WORM, 36T, 6 PITCH, 2 SPEED GEAR BOX
4	8	YWLO12005	WASHER, LOCK, 3/8
5	2	YBHH12035	BOLT, HEX, 3/8-16 X 1-1/4, G5, ZC
6	1	17G107	CAST, HSG, GRBX, LOWER
7	1	17G139	CAP, 1.75
8	1	17G132	KEY, SQ, 0.31 X 0.31 X 2.25
9	1	17G135	SNAP RING, 1.424 ID X .125 WT
10	1	17G136	SHAFT, RND, 1.50, 7.093, WORM GEAR OUTPUT
11	1	5B9	KEY, WDF, 0.38 X 0.53 X 1.25
12	2	YNHX12005	HEX NUT, 3/8-16 GR 2
13	2	17G140	SCR, STUD, 0.38-16 X 1.81
14	1	17G99	CAST, HSG, GRBX, UPPER
15	1	17G108A	SHAFT, RND, 1.75, 12.82, PTO INPUT
16	1	17G111	BSH, 1.75 X 1.5 X 1.0, BRZ
17	1	17G110	GEAR, BEVEL, 16T, WITH 4 JAW
18	2	G18	BRG, 2.24 X 1.58 X .82, TAPER
19	3	G55	RING, SNAP, INTERNAL, 3.02 X 2.64
20	2	18VB25	BEARING, ROLL, CUP, 2.72,
21	1	G68	CAP, 2.72
22	1	17G116	KEY, SQ, 0.25 X 0.25 X 0.63
23	1	17G58	VENT CAP
24	1	12V62	HEAVY DUTY EXTERNAL SNAP RING, 1.50" KEY,
25	1	G61	WDF, 0.38 X 0.55 X 1.25
26	1	YWFL24005	WASHER, FLAT, 3/4 IN USS
27	1	17G104	SHAFT, RND, 1.50, 9.0, BEATER OUTPUT GEAR,
28	1	17G101	BEVEL, 22T
29	2	17G102	BEARING, ROLL, CUP, 2.72,
30	2	17G103	BRG, 2.35 X 1.50 X 0.75, TAPER
31	1	G65	PLUG, PIPE 3/8-18 NPT

FIGURE 13
GEARBOX

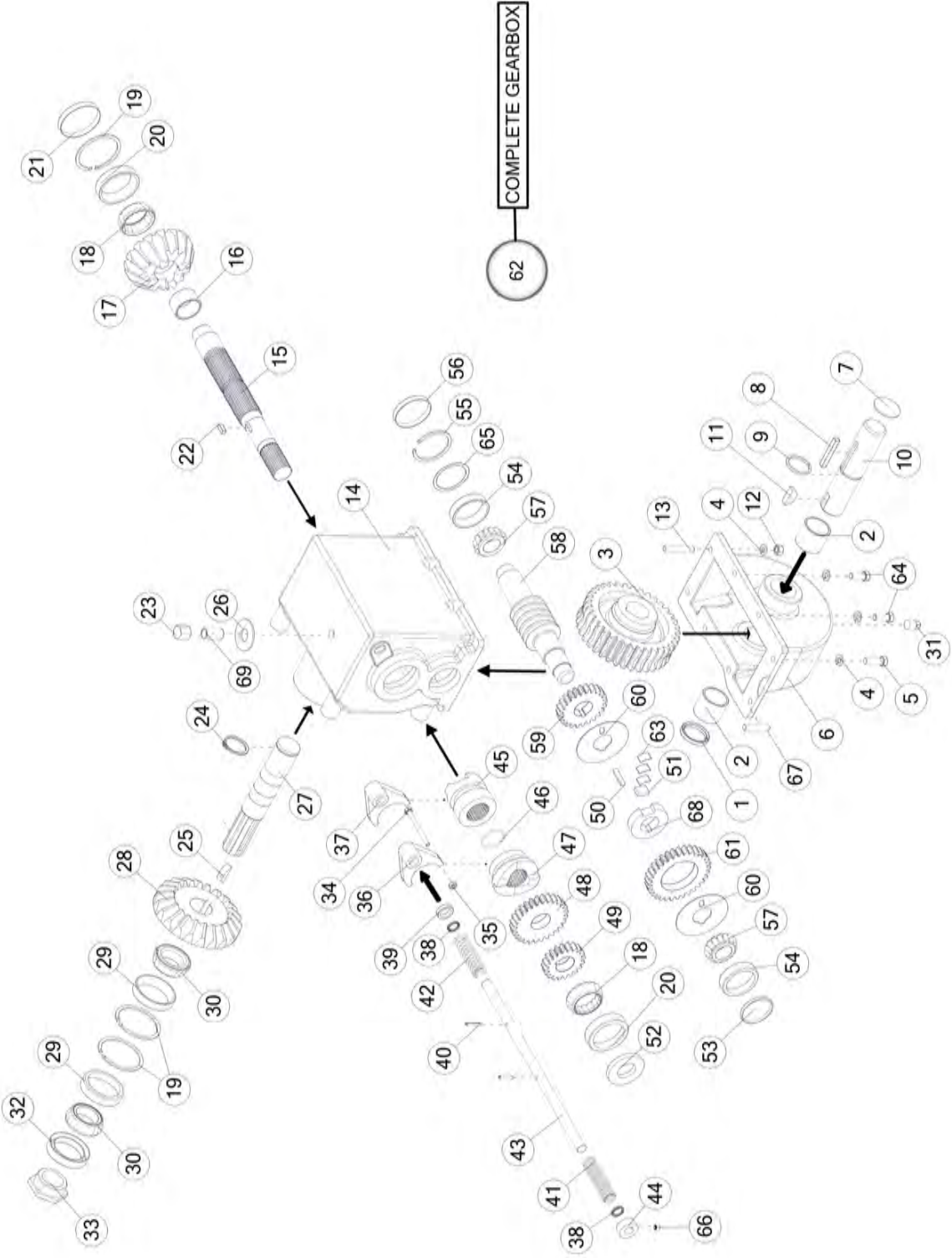

FIGURE 13

GEARBOX

<u>ITEM</u>	<u>QTY</u>	<u>PART #</u>	<u>DESCRIPTION</u>
32	1	17G105	SEAL, 2.72 BORE, 2.00 SHAFT
33	1	17G106	NUT, HEX, 1.50-18, NA
34	1	YBHH08090	BOLT, 1/4 X 3 GR 2 FULL THREAD
35	1	YNHX08007	HEX NUT, 1/4-20 GR 5
36	1	17G125	YOKE, SHIFTER, HIGH SPEED
37	1	17G129	YOKE, SHIFTER, BEATER
38	2	17G121	SEAL, .813 BORE X .625 SHAFT
39	1	17G122	TUBE, RND, STR, 1.06 X 0.14 X 0.25
40	2	17G123	PIN, ROLL, 0.19 X 1.0, ZN
41	1	17G128	SPRG, COIL, 3.36, COMP
42	1	17G130	SPRG, COIL, 3.13, COMP
43	1	17G131	SHAFT, RND, 0.625, 15.0, SHIFTER ROD
44	1	17G171	COLLAR, LOCK, 1.25X.629,
45	1	17G109	BEATER CLUTCH, 2 SPEED GEAR BOX
46	1	17G169A	RING, SNAP, 1.57 X 1.38
47	1	17G119	HIGH SPEED CLUTCH, 2 JAW
48	1	17G118	GEAR, 28T, HIGH SPEED W/2 JAWS GEAR,
49	1	17G115	LOW SPEED, 2 SPEED GEAR BOX
50	1	S135	KEY, SQ, 0.25X0.25X1.25
51	1	17G124	KEY, 0.75 X 0.25 X 0.56
52	1	S136	SEAL, OIL, 1.25 ID X 2.44 OD X .31 THK
53	1	17G100	CAP, 2.14
54	2	3G18	BEARING, ROLL, CUP, 2.54,
55	1	3G19	RING, SNAP, INTERNAL, 2.59 X 2.22
56	1	G90	CAP
57	2	L3G24	BRG, 1.75 X 1.13 X 0.81, TAPER
58	1	17G120	SHAFT, RND, 2.33, 9.84
59	1	17G117	GEAR, HIGH SPEED, 2 SPEED GEARBOX
60	2	17G112	WASH, FLAT, 3.50, 1.26
61	1	17G113	LOW SPEED GEAR, 2 SPEED GEARBOX
62	1	17G142	ASSM, 2 SPEED GEARBOX
63	3	17G126	SPRG, DOG, 0.552 X 0.75
64	4	YBHH12010	BOLT, HEX, 3/8-16 X 1, G5, ZC
65	1	G92	SHIM, STAINLESS, 2.40" OD X 2.00" ID, X .010
66	1	YSKP10015	SET SCREW, SOCKET, KNURLED CUP PT, 5/16 X 5/16
67	1	17G138	SCR, STUD, 0.38-16 X 2.0
68	1	17G114	CLUTCH, LOW SPEED, 2 SPEED GEARBOX
69	1	23N288	PIPE NIPPLE, 0.38 X 1.25

FIGURE 14
HUB ASSEMBLY

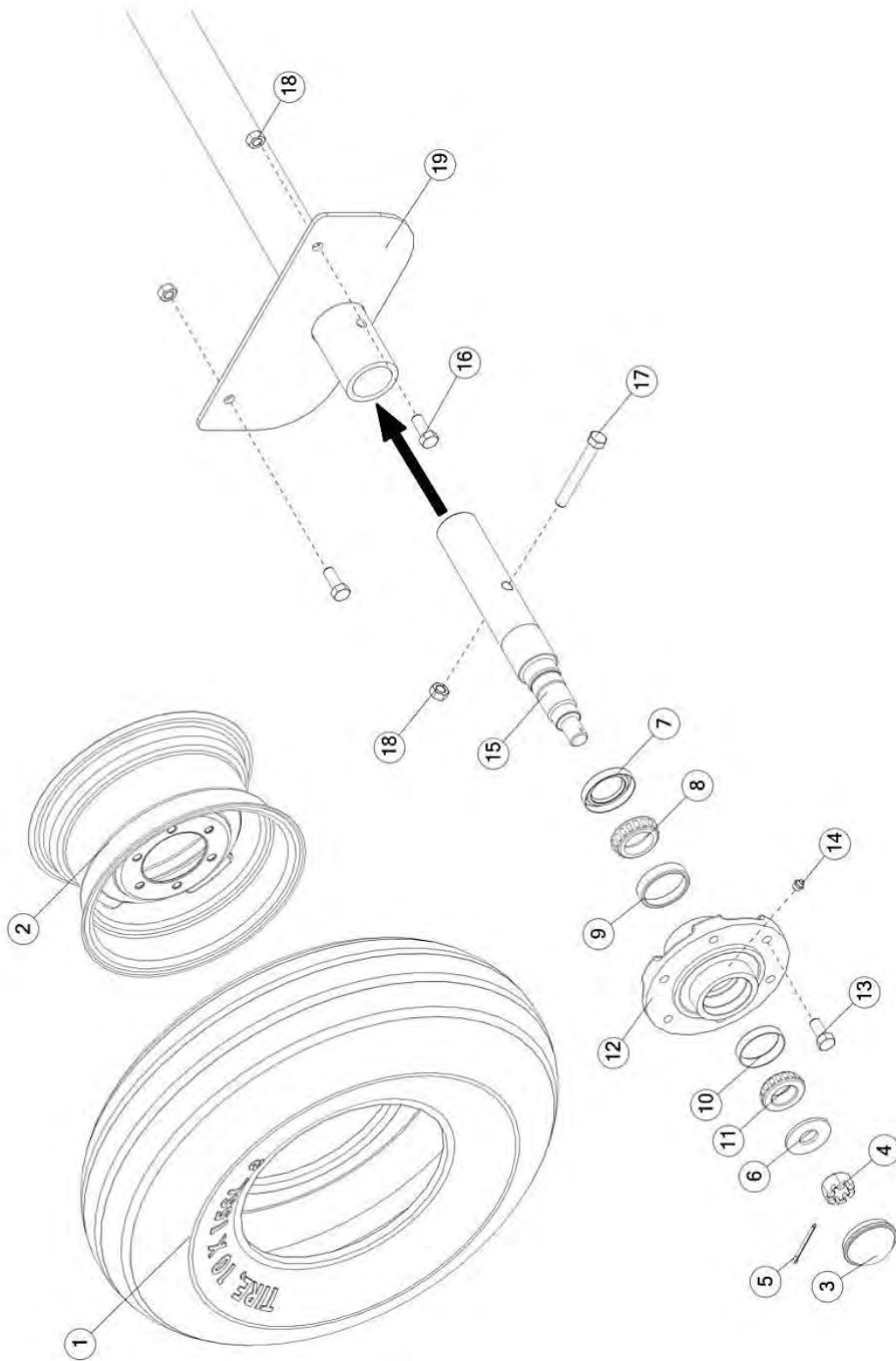

FIGURE 14 HUB ASSEMBLY

<u>ITEM</u>	<u>QTY</u>	<u>PART #</u>	<u>DESCRIPTION</u>
1	2	UR9	10.00 X 15 TUBELESS -8 PLY
2	2	12N24	WHEEL, 15 X 8, 6-BOLT, 1.125+ OFFSET
*	2	72436	VALVE STEM, 1-1/2" RUBBER
3	2	17G144	HUB CAP
4	2	YNSL28005	HEX NUT, SLOTTED, 7/8-14
5	2	YPCT05010	COTTER PIN 5/32" X 1-1/2"
6	2	YWFL28005	WASHER, FLAT, 7/8 USS, ZINC
7	2	12N17	SEAL
8	2	12N18	INNER BEARING
9	2	12N19	INNER RACE
10	2	17G146	OUTER RACE
11	2	17G145	OUTER BEARING
12	2	12N20	ASSM, HUB 888, WITH RACES
13	12	YBWL16005	BOLT,WHEEL,1/2-20X1,GR5,ZC
14	2	BFR28	1/8" NPT GREASE ZERK
15	2	12N16	2.00" X 14.000" SPINDLE FOR 888 HUB
16	4	YBHH16045	BOLT, 1/2-13 X 1-1/4 GR 5
17	2	YBHH16120	BOLT, 1/2 X 3-1/4 GR 5
18	6	YNNY16005	HEX NUT, NYLON LOCKNUT, 1/2
19	1	67319	WLDMT, AXLE, S2112

***MEANS NOT SHOWN**

FIGURE 15
PTO

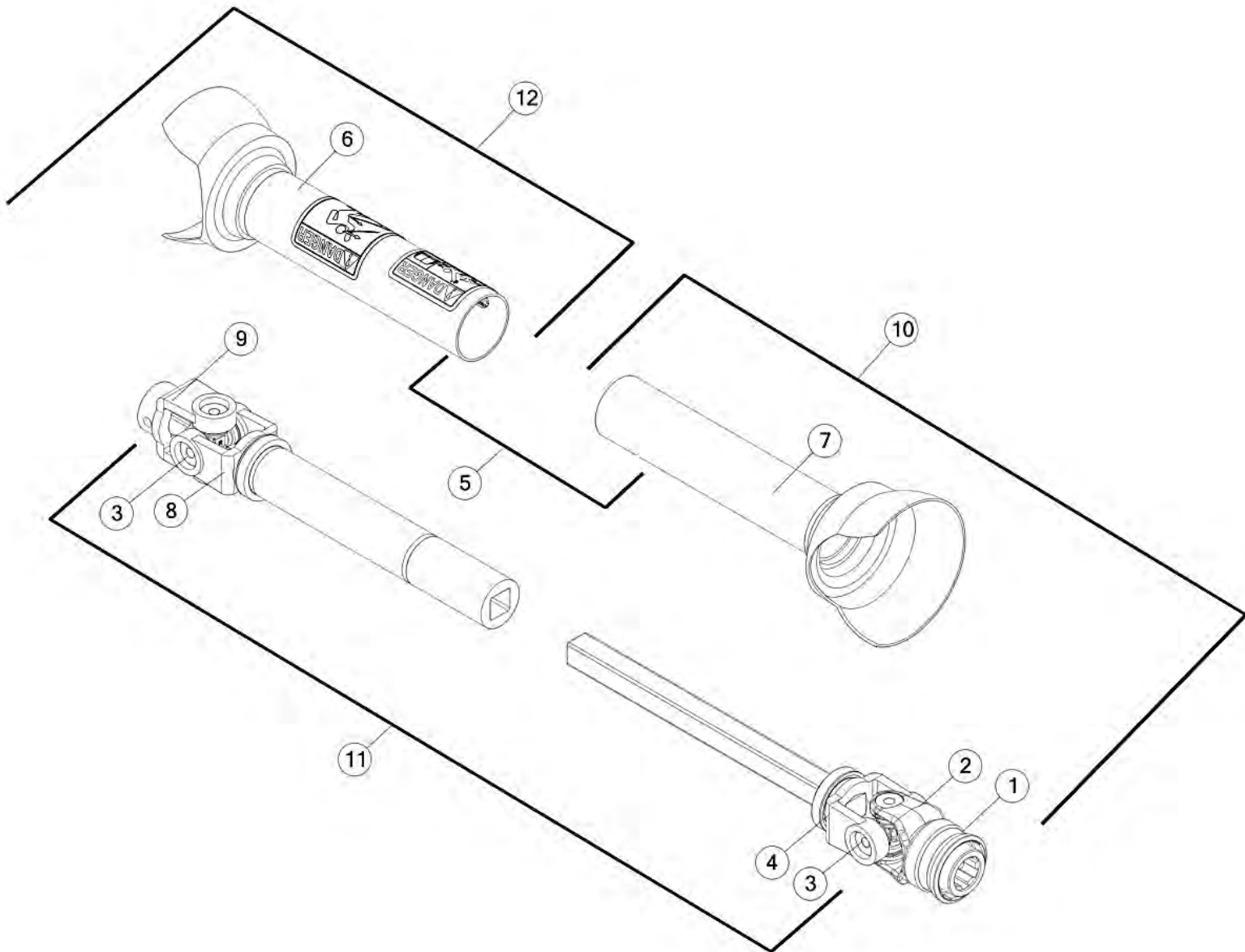

FIGURE 15

PTO

<u>ITEM</u>	<u>QTY</u>	<u>PART #</u>	<u>DESCRIPTION</u>
1	1	S225	SPRING-LOK REPAIR KIT
2	1	S379	SPRING-LOK YOKE ASSEMBLY
3	2	T274	12P CROSS AND BEARING KIT
4	1	12N110	YOKE AND SHAFT
5	2	S206	GUARD REPAIR KIT (NOT SHOWN)
6	1	12N112	INNER GUARD
7	1	12N111	OUTER GUARD
8	1	12N113	YOKE AND TUBE
9	1	12N115	YOKE
10	1	12N106	JOINT & SHAFT HALF ASSEMBLY W/ GUARD
11	1	12N102	COMPLETE PTO ASSEMBLY
12	1	12N109	JOINT & TUBE HALF ASSEMBLY W/ GUARD
*	1	S402	PTO SAFETY MANUAL

***MEANS NOT SHOWN**

FIGURE 16
OPTIONAL PAN

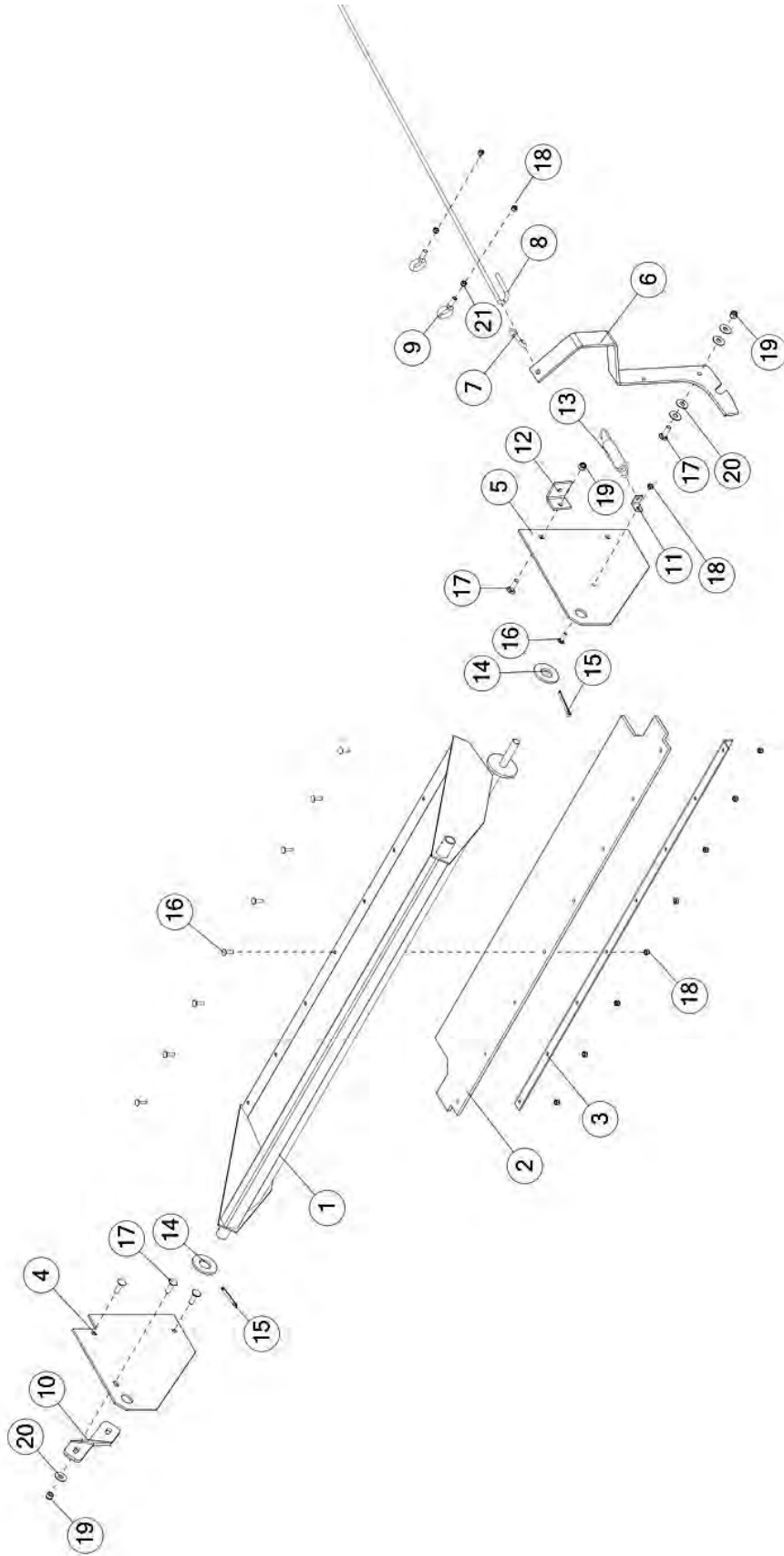
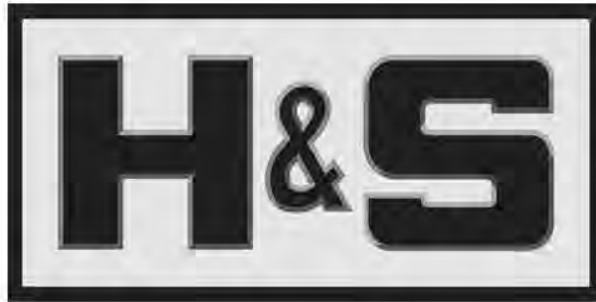

FIGURE 16 OPTIONAL PAN

<u>ITEM</u>	<u>QTY</u>	<u>PART #</u>	<u>DESCRIPTION</u>
1	1	71414	WLDMNT, 125 PAN, GEAR BOX, LH
2	1	12N53	PAN RUBBER
3	1	12N52	RUBBER FLAP ANGLE
4	4	71411	PLT, 12.0, 12.0, 0.19, PAN LH
5	1	12N56	PAN SUPPORT, LH
6	1	71413	PLT, REAR PAN HANDLE
7	1	YMHK92004	S-HOOK .262" DIA. X 2" X 9/16" OPEN
8	1	80N6	ROPE, 0.31 X 134
9	2	YBTE08005	BOLT, TURNED EYE, 1/4-20X1
10	1	71426	PLT, 1.75x.25, PAN BRACE
11	1	R26	SPRING ANGLE
12	1	RP10	2" ANGLE
13	1	R27	SPRING
14	2	R3	WASH, FLAT, 2.38 X 1.13 X 0.19, NF
15	2	YPCT08007	COTTER PIN, 1/4 X 2
16	9	YBCR08005	BOLT, CARR, 1/4-20 X 1.00, G5, ZC
17	5	YBCR12020	BOLT, CARR, 3/8-16 X 1-1/4, G5, ZC
18	11	YNNY08005	NUT, HEX, 1/4-20, LKNY, G2, ZC
19	1	YNNY12005	NUT, HEX, 3/8-16, LKNY, G2, ZC
20	5	YWFL14005	WASHER, FLAT, 7/16 USS, ZINC
21	2	YNHX08005	NUT, HEX, 1/4-20, NA, A, ZC



**H&S Manufacturing products are approved for the
FEMA SEAL OF QUALITY**

**P.O. BOX 768, MARSHFIELD, WI 54449
(715) 387-3414 FAX (715) 384-5463
www.hsmfgco.com**